

# Moonlight Pendelleuchte [MPL]

Pendelleuchten eröffnen völlig neue Möglichkeiten der Lichtgestaltung bei Innen- oder Außenanlagen und bereichern moderne und klassische Architektur.

Das Standardkabel mit integriertem Stahlseil hat eine Mindestbruchkraft von ca. 3700 kN.

## Highlights

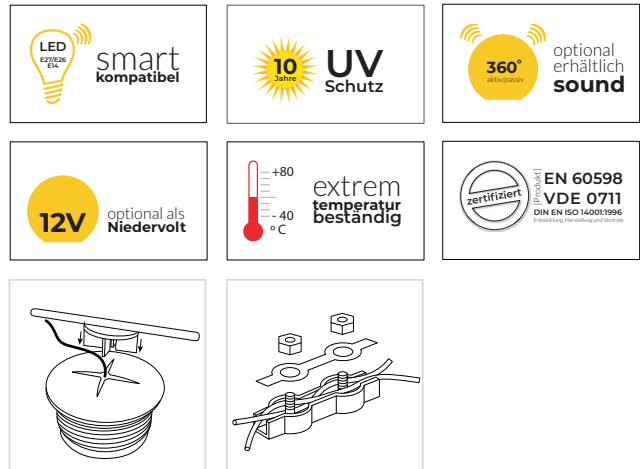

Pendant lights open up completely new lighting design options for indoor and outdoor areas and enrich modern and classic architecture.

*The standard cable with integrated steel cable has a minimum breaking strength of approx. 3700 kN.*

Modell	MPL-3500	MPL-5500	MPL-7500
Durchmesser/Diameter	ø 350 mm / 13.7795"	ø 550 mm / 21.6535"	ø 750 mm / 29.5276"
Öffnung/Aperture	ø 56 mm / 2.20472"	ø 108 mm / 4.25197"	ø 159 mm / 6.25984"
Farben/Color	weiß, granit hell, granit dunkel, sandstein		
Fassung/Light Fitting	E27/E26		
Kabellänge/Cable length	3 m, optional 10 m, 20 m		
Nennspannung/Voltage	230 V / 120 V		
Schutzart/Ingress protection	IP 66		
Schutzklasse/Protection class	II		
Gewicht	2,7 kg	6 kg	11,5 kg
EAN	4055058030604	4055058050602	4055058070600

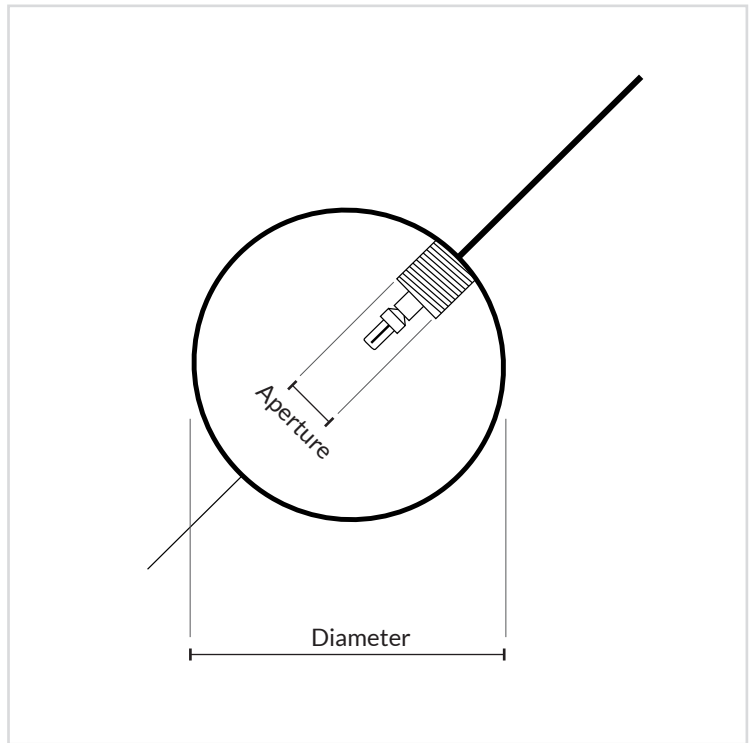
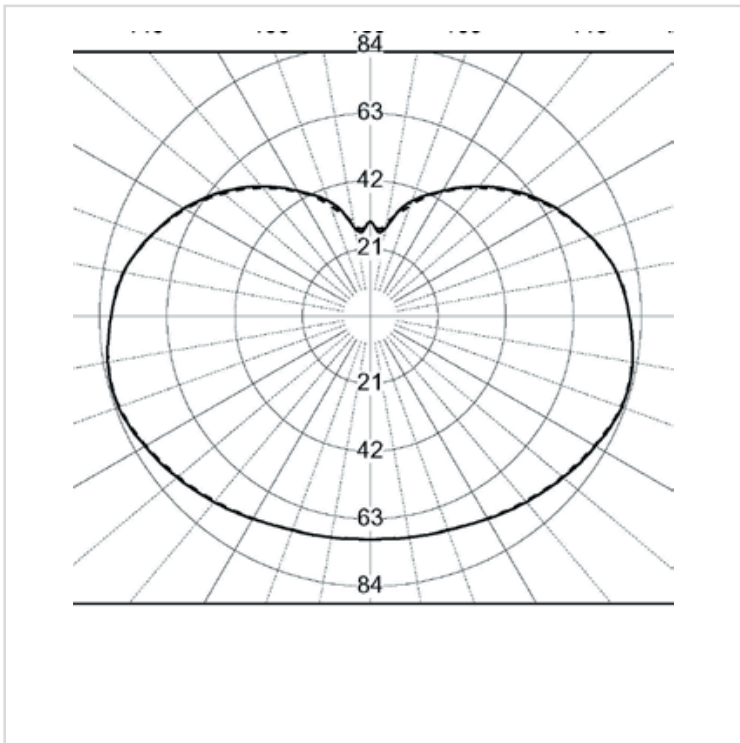

# Moonlight Spannleuchte [MPLF]

Spannleuchten eröffnen völlig neue Möglichkeiten der Lichtgestaltung bei Innen- oder Außenanlagen und bereichern moderne und klassische Architektur.

Das Standardkabel mit integriertem Stahlseil hat eine Mindestbruchkraft von ca. 3700 kN.

## Highlights

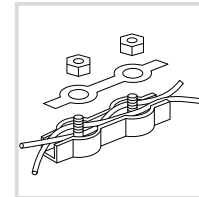
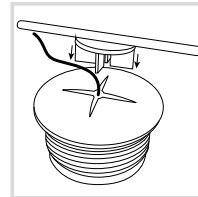
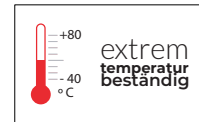
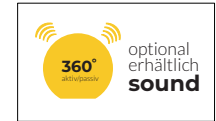

Tension lights open up completely new possibilities for lighting design in indoor and outdoor areas and enrich modern and classic architecture.

*The standard cable with integrated steel cable has a minimum breaking strength of approx. 3700 kN.*

Modell	MPLF-3500	MPLF-5500	MPLF-7500
Durchmesser/Diameter	ø 350 mm / 13.7795"	ø 550 mm / 21.6535"	ø 750 mm / 29.5276"
Öffnung/Aperture	ø 56 mm / 2.20"	ø 108 mm / 4.25197"	ø 159 mm / 6.25984"
Farben/Color	weiß, granit hell, granit dunkel, sandstein		
Kabellängen/Cable length	3 m, optional 10 m, 20 m		
Fassung/Light Fitting	E27/E26		
Nennspannung/Voltage	230 V / 120 V		
Schutzart/Ingress protection	IP 66		
Schutzklasse/Protection class	II		
Gewicht	2,6 kg	6,1 kg	11,6 kg
EAN	4055058130809	4055058150807	4055058170805

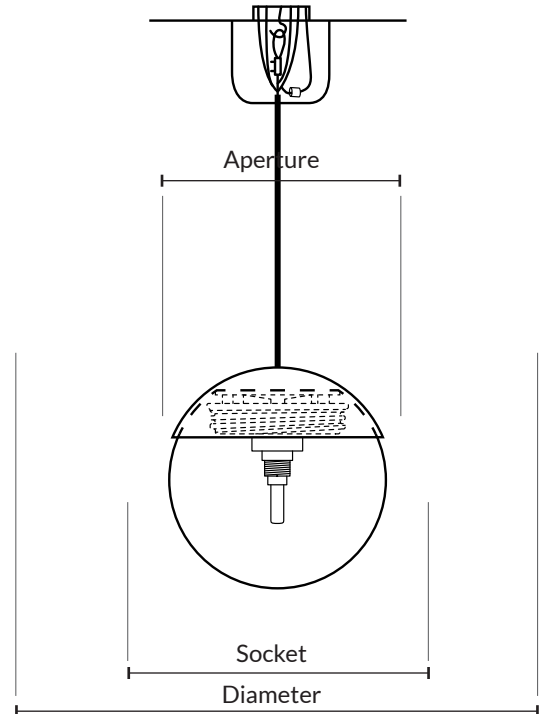
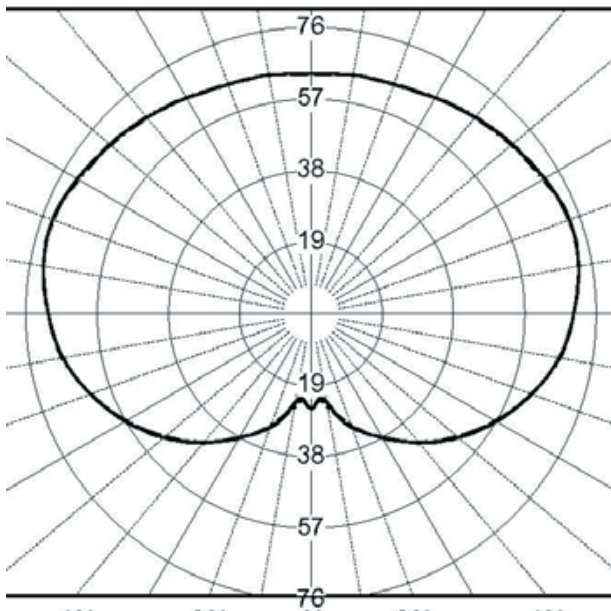

# Moonlight Sound Pendelleuchten [MPLS]

## Hängeleuchte Ambientlicht mit Sound

Die Moonlight Sound Modelle verbinden das einzigartig weiche Moonlight Licht mit dezentem und sattem Sound. Das macht sie auch in Innenräumen zu einem praktisch unsichtbaren Lautsprecher, der sich wahlweise mit Bluetooth ansteuern lässt (Aktive Sound) oder in ein vorhandenes Raum-Soundsystem integriert werden kann (Passive Sound).

Da die Moonlight Sound wie alle Moonlights UV- und spritzwassergeschützt sind, sind sie auch die erste Wahl für den Aussenbereich von Restaurants, oder für Hotel-Lobbys, Empfangs- und Aufenthaltsbereiche.

## Highlights



## Ambient light with sound

*The Moonlight Sound models combine the uniquely soft Moonlight light with a subtle and rich sound. This makes it a practically invisible loudspeaker indoors, which can be controlled either with Bluetooth (active sound) or integrated into an existing room sound system (passive sound).*

*Since the Moonlight Sound, like all Moonlights, is UV and splash-proof, they are also the first choice for the outside area of restaurants, or for hotel lobbies, reception and lounge areas.*

Modell	MPLS-3500	MPLS-5500	MPLS -7500
Durchmesser/Diameter	ø 350 mm / 13.7795"	ø 550 mm / 21.6535"	ø 750 mm / 29.5276"
Sockel/Socket	n.a.	n.a.	n.a.
Öffnung/Aperture	n.a.	n.a.	n.a.
Farben/Color	weiß, granit hell, granit dunkel, sandstein		
Fassung/Light Fitting	E27/E26		
Nennspannung/Voltage	230 V / 120 V		
Schutzart/Ingress protection	IP 54		
Schutzklasse/Protection class	II		
Nominal	4 Ω	4 Ω	4 Ω
Power	60 RMS / 120W	75 RMS / 150W	100 RMS / 200W
Frequenz	60 bis 20000 Hz	50 bis 20000 Hz / Hrs.	40 bis 20000 Hz / Hrs.
Sensitivity	90 db 1w@1m	90 db 1w@1m	90 db 1w@1m
Kabel/Cable	3 m Stromkabel + 3 m (2,5 qmm) Lautsprecherkabel		
Gewicht	n.a.	n.a.	n.a.
EAN	n.a.	n.a.	n.a.