

# Moonlight with Surface Base [MAG UL]

## Floor or wall lamp for installation to the ground

This Moonlight lamp is firmly screwed to the surface or the wall. It can be used both inside and outside and immerses its surroundings in the characteristic soft Moonlight light.

Luminaires with a screw-on base are supplied without a cable, which can be permanently laid, installed safely and permanently on site by your electrician.

## Highlights

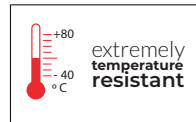

Modell	MAG-2500.2	MAG-3500.2	MAG-5500.2	MAG-7500.2
<b>Durchmesser/ Diameter</b>	ø 250 mm / 9.85"	ø 350 mm / 13.7795"	ø 550 mm / 21.6535"	ø 750 mm / 29.5276"
<b>Sockel/Socket</b>	ø 149 mm / 5.86614"	ø 210 mm / 8.26772"	ø 318 mm / 12.5197"	ø 438 mm / 17.2441"
<b>Öffnung/ Aperture</b>	ø 51 mm / 2.00787"	ø 78 mm / 3.07087"	ø 78 mm / 3.07087"	ø 78 mm / 3.07087"
<b>Lochkreis/ Hole Circle</b>	ø 106 mm / 4.17323"	ø 161 mm / 6.33858"	ø 254 mm / 10"	ø 330 mm / 12.9921"
<b>Farben/Color</b>	white, granite light, granite dark, sandstone			
<b>Fassung/ Light Fitting</b>	E26			
<b>Nennspan- nung/Voltage</b>	120 V			
<b>Schutzart/ Ingress protection</b>	IP 66			
<b>Schutzklasse/ Protection class</b>	II			
<b>Gewicht/ Weight</b>	1,2 kg	2,5 kg	6,1 kg	11,6 kg
<b>EAN</b>	4055058020209	4055058030208	4055058050206	4055058070204

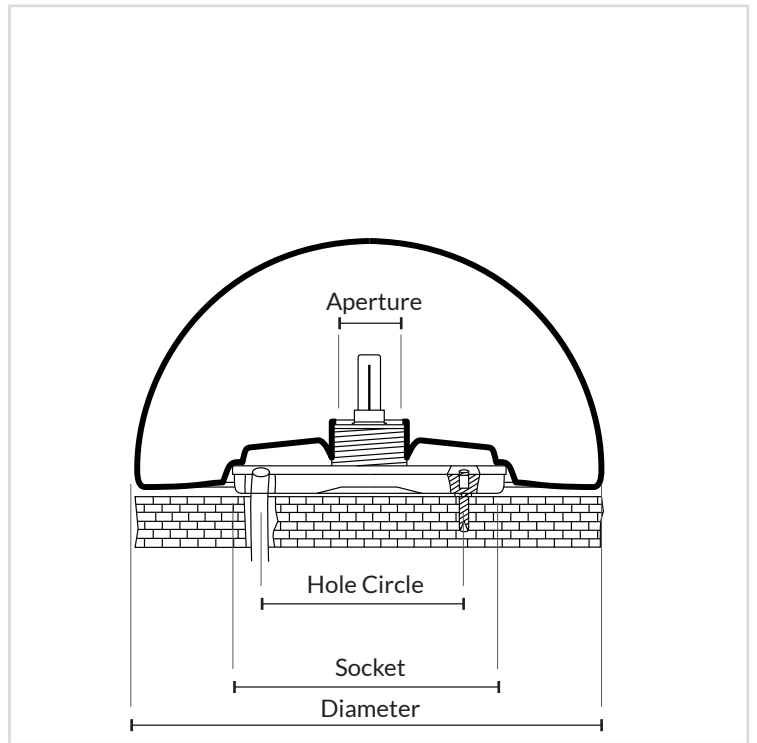
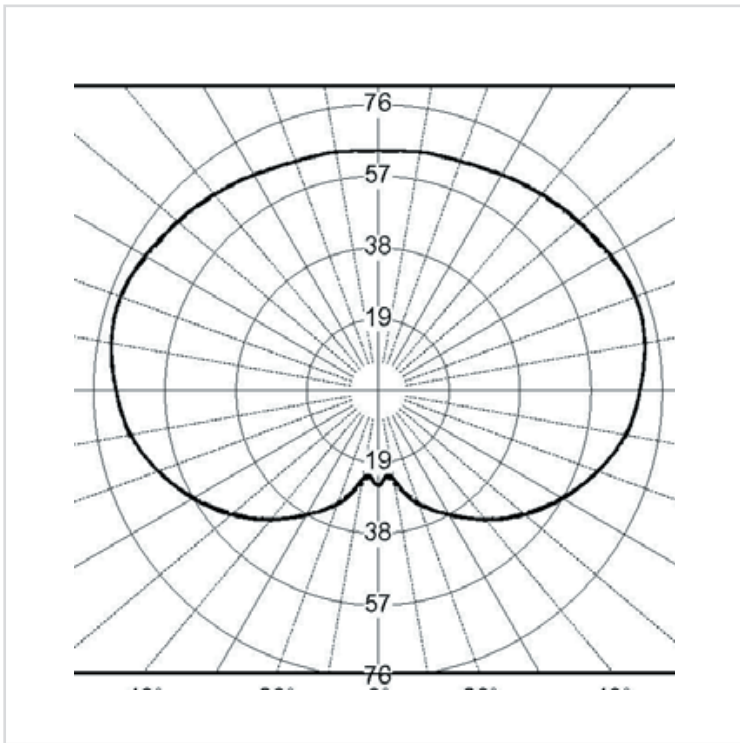

# Hemisphere with Surface Base [HMAG UL]

## Hemispherical floor or wall light for installation to the ground

This Moonlight hemisphere lamp is firmly screwed to the surface or the wall. It can be used both inside and outside and immerses its surroundings in the characteristic soft Moonlight light.

Luminaires with a screw-on base are supplied with a cable, which can be permanently installed by your local electrician.

## Highlights

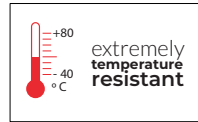

Modell	HMAG-3500.2	HMAG-5500.2	HMAG-7500.2
Durchmesser/Diameter	ø 350 mm / 13.7795"	ø 550 mm / 21.6535"	ø 750 mm / 29.5276"
Sockel/Socket	ø 250 mm / 9.84"	ø 317 mm / 12.4803"	ø 438 mm / 17.2441"
Öffnung/Aperture	ø 78 mm / 3.07087"	ø 78 mm / 3.07087"	ø 78 mm / 3.07087"
Lochkreis/Hole Circle	ø 196 mm / 7.71654"	ø 258 mm / 10.1575"	ø 330 mm / 12.9921"
Farben/Color	white, granite light, granite dark, sandstone		
Fassung/Light Fitting	E26		
Nennspannung/Voltage	120 V		
Schutzart/Ingress protection	IP 66		
Schutzklasse/Protection class	II		
Gewicht/Weight	2,3 kg	4,5 kg	9,6 kg
EAN	4055058040207	4055058060205	4055058080203

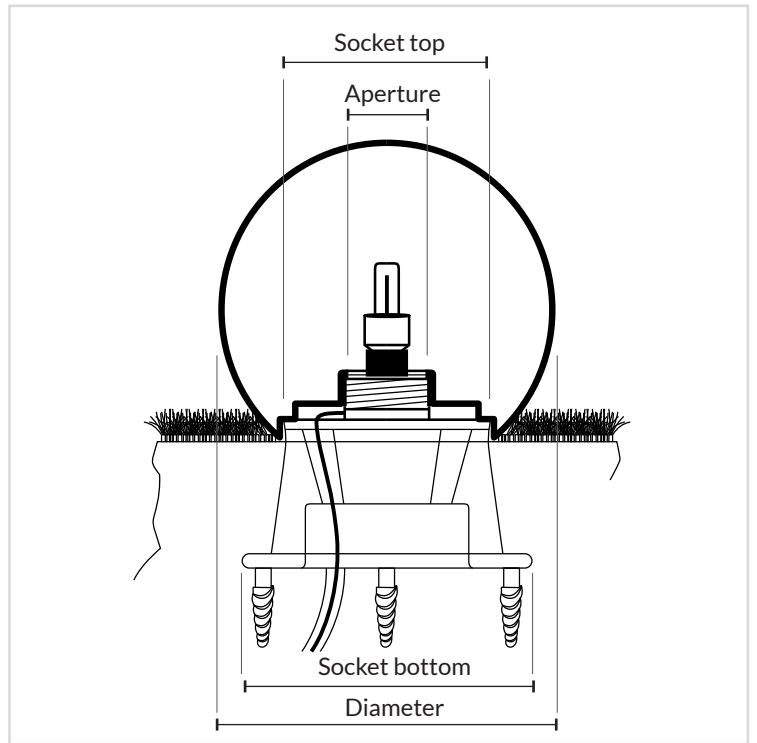
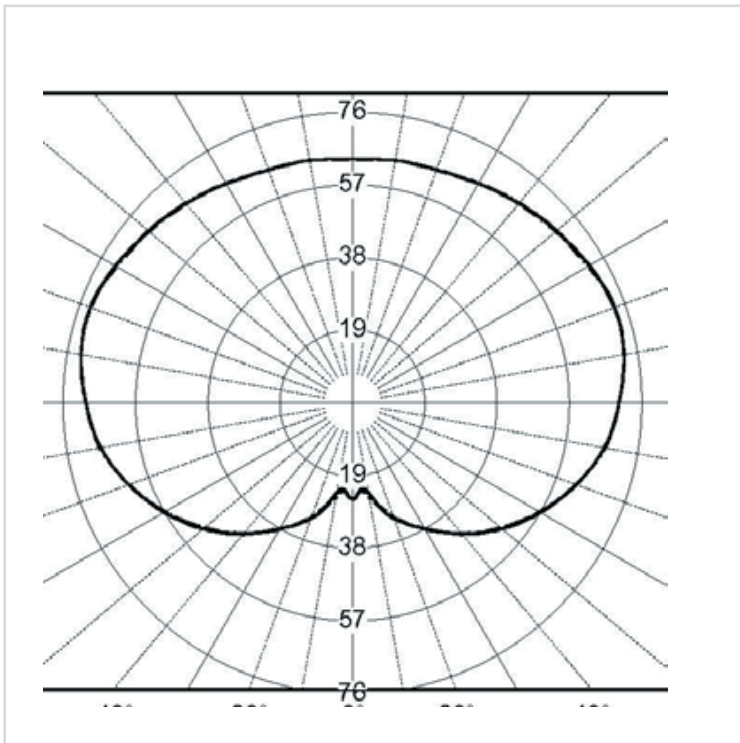

# Moonlight with Sub-Surface Base [MBG UL]

## Moonlight Luminaire for permanent installation in the ground.

Installation with a sub-surface base requires laying the cable in the ground (not included in the scope of delivery).

Ground dowels can be used on less solid ground and to secure against twisting.

## Highlights

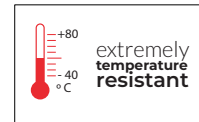

Modell	MBG-2500.2	MBG-3500.2	MBG-5500.2	MFL-7500.2
<b>Durchmesser/ Diameter</b>	ø 250 mm / 9.84252"	ø 350 mm / 13.7795"	ø 550 mm / 21.6535"	ø 750 mm / 29.5276"
<b>Sockel oben/ Socket top</b>	ø 149 mm / 5.86614"	ø 210 mm / 8.26772"	ø 318 mm / 12.5197"	ø 438 mm / 17.2441"
<b>Sockel unten/ Socket bottom</b>	ø 215 mm / 8.46457"	ø 300 mm / 11.811"	ø 466 mm / 18.3465"	ø 636 mm / 25.0394"
<b>Sockel Höhe/ Socket height</b>	135 mm / 5.31"	135 mm / 5.31"	135 mm / 5.31"	135 mm / 5.31"
<b>Öffnung/ Aperture</b>	ø 51 mm / 2.01"	ø 78 mm / 3.07087"	ø 78 mm / 3.07087"	ø 78 mm / 3.07087"
<b>Farben/Color</b>	white, granite light, granite dark, sandstone			
<b>Fassung/ Light Fitting</b>	E26			
<b>Nennspannung/ Voltage</b>	120 V			
<b>Schutzart/ Ingress protection</b>	IP 66			
<b>Schutzklasse/ Protection class</b>	II			
<b>Gewicht/Weight</b>	1,6 kg	3,3 kg	7,5 kg	14,7 kg
<b>EAN</b>	4055058020407	4055058040405	4055058060403	4055058080401

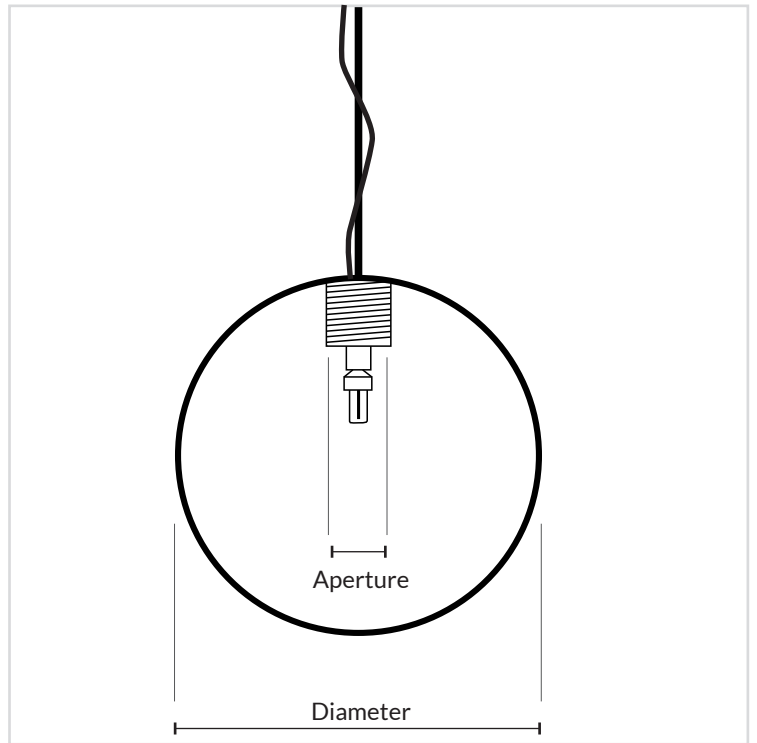
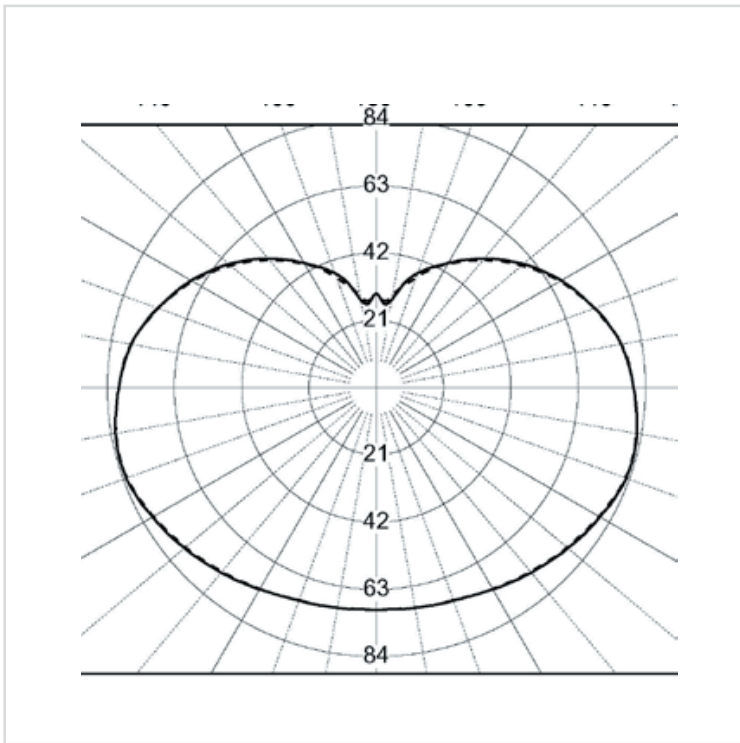
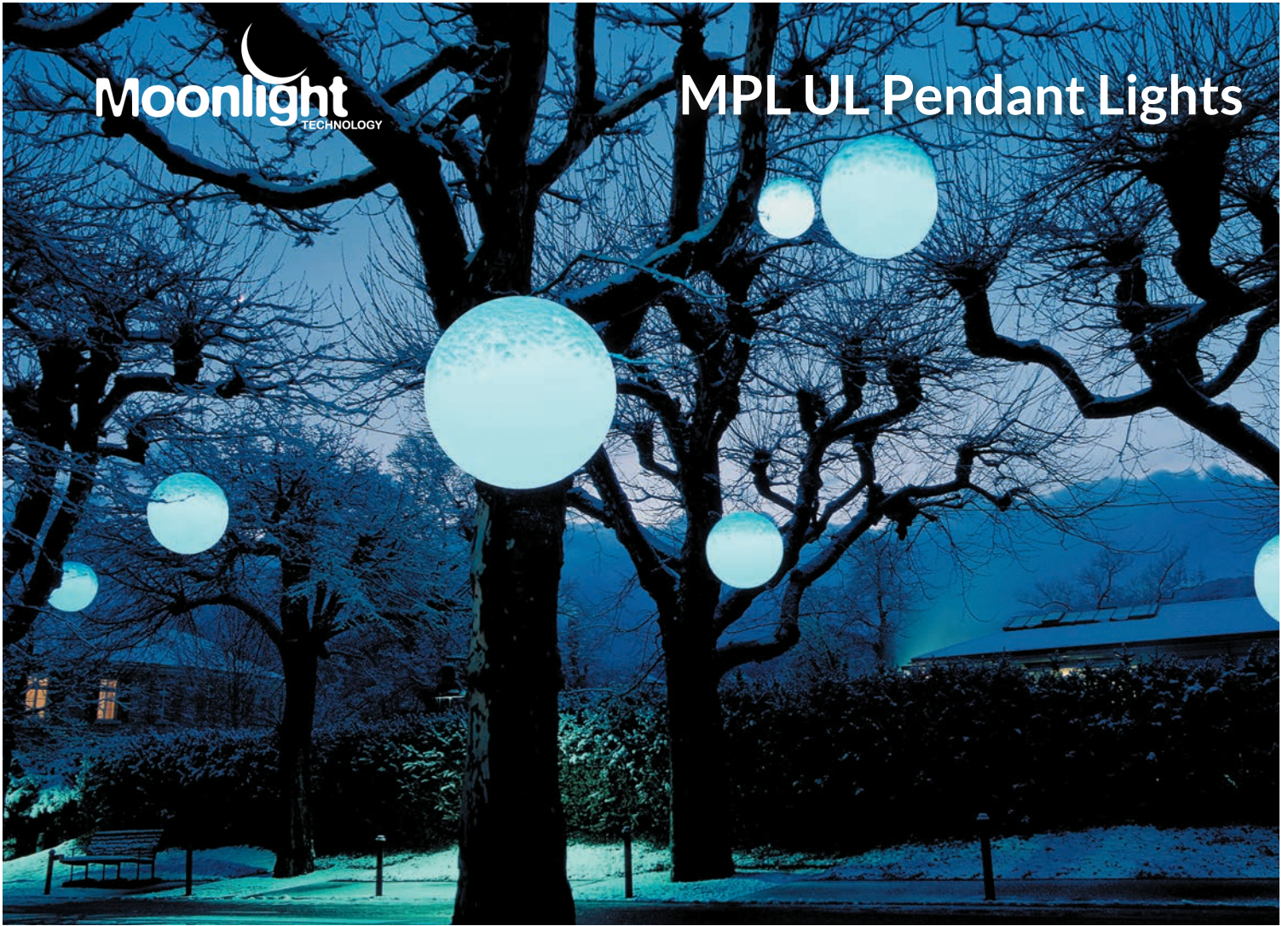

# Moonlight Pendant Lights [MPL UL]

Pendant lights open up completely new lighting design options for indoor and outdoor areas and enrich modern and classic architecture.

The standard cable with integrated steel cable has a minimum breaking strength of approx. 3700 kN.

## Highlights

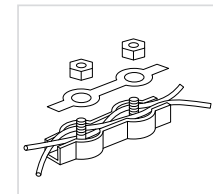
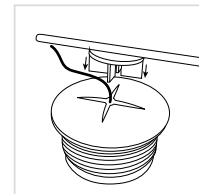
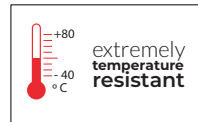

Modell	MPL-3500.2	MPL-5500.2	MPL-7500.2
Durchmesser/Diameter	ø 350 mm / 13.7795"	ø 550 mm / 21.6535"	ø 750 mm / 29.5276"
Öffnung/Aperture	ø 56 mm / 2.20472"	ø 108 mm / 4.25197"	ø 159 mm / 6.25984"
Farben/Color	white, granite light, granite dark, sandstone		
Fassung/Light Fitting	E26		
Kabellänge/Cable length	3 m, optional 10 m, 20 m		
Nennspannung/Voltage	120 V		
Schutzart/Ingress protection	IP 66		
Schutzklasse/Protection class	II		
Gewicht/Weight	2,7 kg	6 kg	11,5 kg
EAN	4055058030604	4055058050602	4055058070600



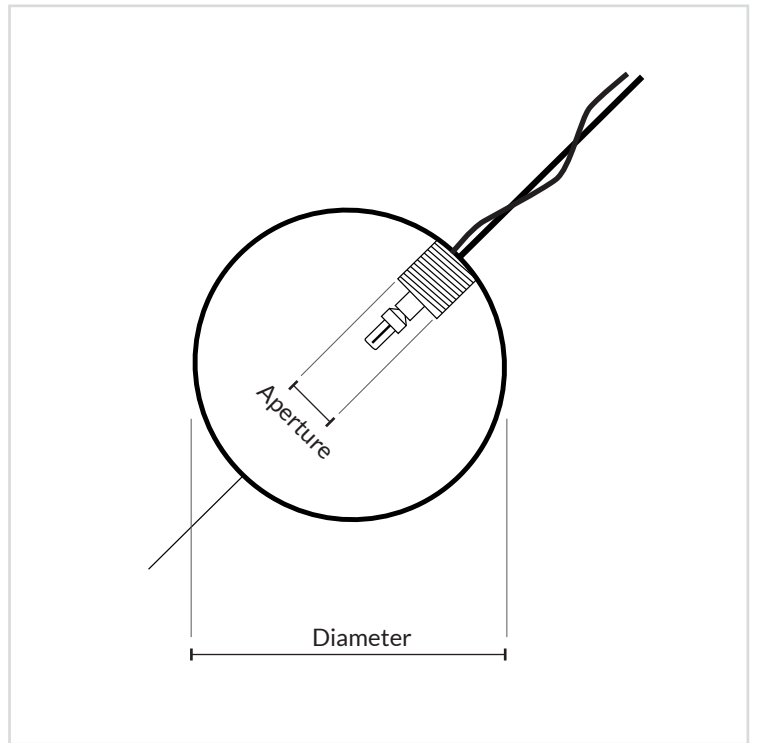
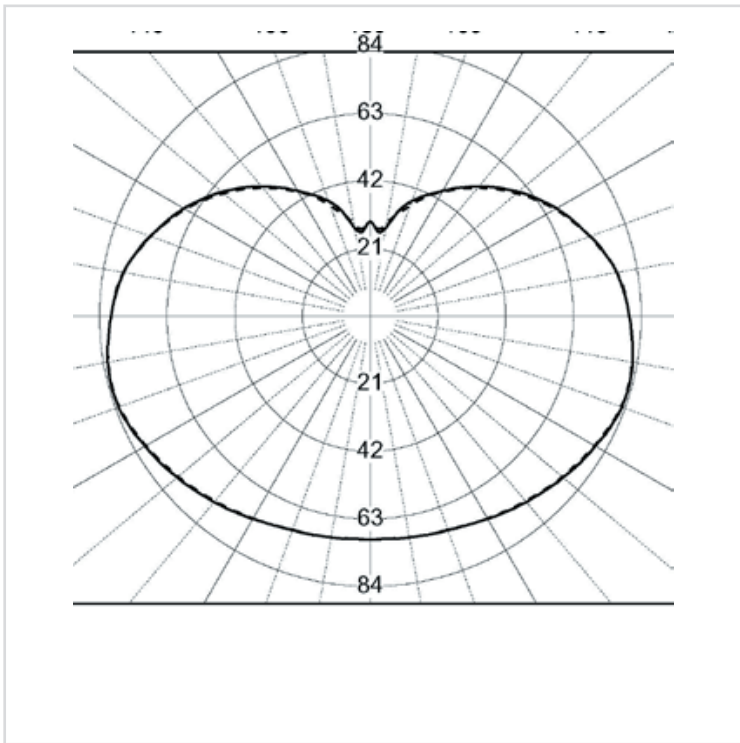

# Moonlight Tension Lights [MPLF UL]

Tension lights open up completely new possibilities for lighting design in indoor and outdoor areas and enrich modern and classic architecture.

The standard cable with integrated steel cable has a minimum breaking strength of approx. 3700 kN.

## Highlights

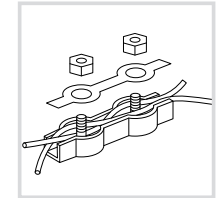
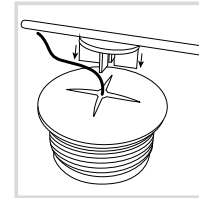
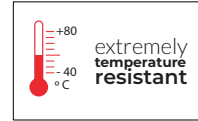

Modell	MPLF-3500.2	MPLF-5500.2	MPLF-7500.2
Durchmesser/Diameter	ø 350 mm / 13.7795"	ø 550 mm / 21.6535"	ø 750 mm / 29.5276"
Öffnung/Aperture	ø 56 mm / 2.20"	ø 108 mm / 4.25197"	ø 159 mm / 6.25984"
Farben/Color	white, granite light, granite dark, sandstone		
Kabellängen/Cable length	3 m, optional 10 m, 20 m		
Fassung/Light Fitting	E26		
Nennspannung/Voltage	120 V		
Schutzart/Ingress protection	IP 66		
Schutzklasse/Protection class	II		
Gewicht/Weight	2,6 kg	6,1 kg	11,6 kg
EAN	4055058130809	4055058150807	4055058170805